

Dual

Audiophile Concept



Dual CS 505-3

Dual CS 505-3 Turntable

"This turntable impresses the listener with powerful, well defined bass tones and beautifully balanced, finely drawn mid-range and high frequency reproduction. Choral operas and ecstatic orchestral passages are reproduced sweetly and transparently. And pop music benefits from the grippingly convincing quality of reproduction.

Compared to the less expensive models, this turntable really allows you to enjoy music at its best."

Only the technical information need be added to this profound verdict:

The extremely light ULM tonearm is very insensitive to vibrations and is distinguished by strikingly low harmonic distortion and excellent record protection properties.

A four point gimbal bearing (gyroscopic suspension) guarantees optimum balance of the tonearm in all directions.

The tracking force of the tonearm is adjusted by a torsion spring. The inertia-free principle maintains the tracking force at a constant level in all situations.

All common 1/2" headshells can be mounted.

The full-size floating chassis reduces the low frequency oscillation caused by acoustic feedback and foot noise.

The completely flat anti-resonance turntable mat filters out resonances transmitted from the record and ensures clear and impressive bass reproduction.

The turntable unit consists of a 16-pole synchronous motor which transmits its power via belt to the precision made flange on the platter.

The platter speed (33/45 rpm) can be adjusted by 12%.

The tracking force of the viscosity-damped tonearm can be freely adjusted. The pilot-lift technique keeps the tonearm lifted before start, and the automatic stop function lifts the arm when the record is finished and stops the turntable.

The lid of the unit effectively protects the turntable from dust.



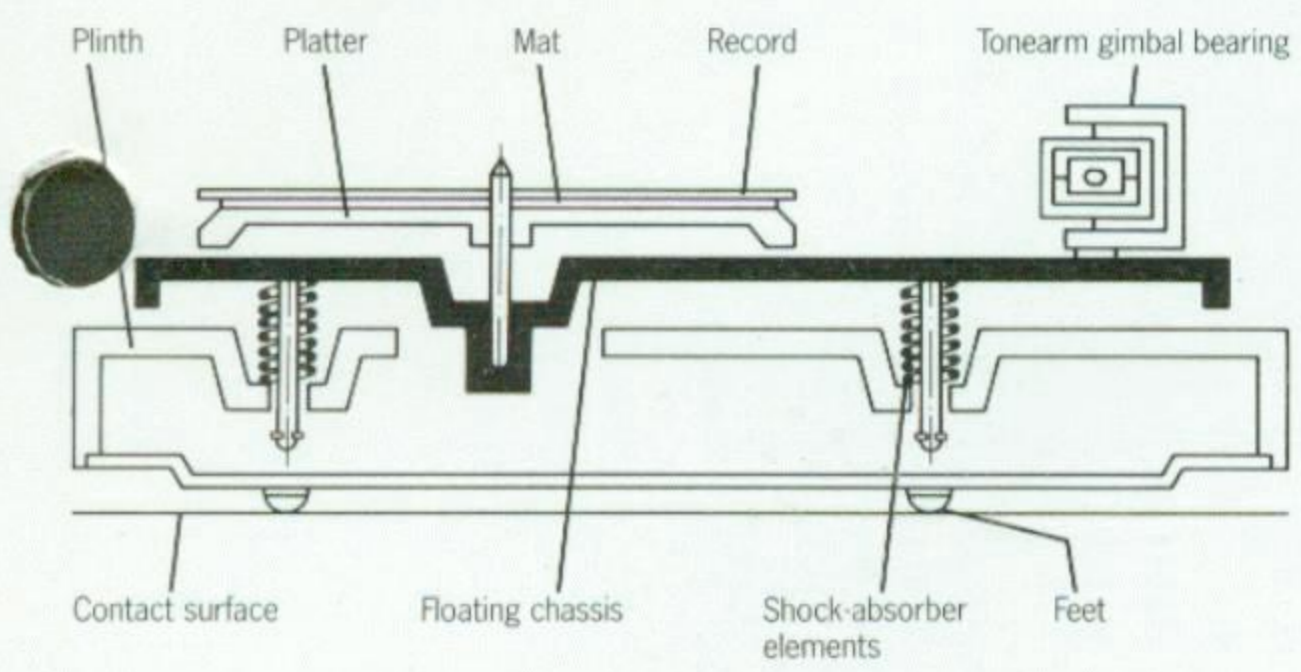

CS 505-3 uses a floating chassis which – together with the tonearm and the platter – is almost completely separated from the turntable casing. Only the shock-absorber feet connect the chassis with the casing. Thanks to their optimum oscillation and damping capabilities, the shock-absorbing feet eliminate both footstep noise and acoustic feedback.



The Dual CS 505-3 turntable comes in walnut finish or black.

HiFi Belt Drive Turntables**CS 505-3**

Type of turntable	HiFi semi autom. turntable
Motor	16pole Synchronous
Drive system	Belt
Speed rpm	33/45
Wow and flutter \pm % DIN/WRMS	0.06/0.035
Rumble dB	52
Signal-to-noise ratio	75
Cartridge system*	Dual ULM 65 E
Rated tracking force mN (10 mN = 1 p)	15
Frequency range (Hz)	10 - 25 000
Low freq. trackability (300 Hz) μ m	80
High freq. trackability (10 kHz) %	0.55
Dimensions (width x height x depth) mm	440 x 138 x 368
Mains voltage V	230 or 115
Mains frequency	50 or 60
Finish	wooden console with genuine veneer walnut or black

* May differ in your country